

Typical Performance

FEATURES

- Wide Input voltage range (2:1/4:1)
- Typical Efficiency:85%
- Switching frequency: 300KHz
- Output Over current protect,Short circuit protection
- input under voltage protection,over voltage protection
- input-output isolated
- PCB Board in-line type installs
- High reliability
- Optional heat sink



3-Years Product Warranty

Technology parameter Test condition:General Nominal Line,Tc=25°C , Rated resistant load unless other wisespecified

| Input Features | Min | Nom | Max | Notes |
|--------------------------------|----------------|-----|-----|-------|
| | Test condition | | | |
| Start voltage | 12V(9~18V) | | | 9V |
| | 18V(9~36V) | | | 10V |
| | 24V(18~36V) | | | 18V |
| | 36V(18~72V) | | | 18V |
| | 48V(36~72V) | | | 36V |
| | 110V(65~150V) | | | 65V |
| | 300V(200~400V) | | | 200V |
| Input under voltage protection | 12V(9~18V) | | | 8V |
| | 18V(9~36V) | | | 8V |
| | 24V(18~36V) | | | 17V |
| | 36V(18~72V) | | | 17V |
| | 48V(36~72V) | | | 35V |
| | 110V(65~150V) | | | 64V |

| | | | | |
|---------------------|---------------------|-----|-----|-------|
| | 300V(200~400V) | | | 199V |
| Input voltage (Vdc) | 9 | 12 | 18V | W 2:1 |
| | 9 | 18 | 36 | W 4:1 |
| | 18 | 24 | 36 | W 2:1 |
| | 36 | 48 | 72 | W 2:1 |
| | 65 | 110 | 150 | W 2:1 |
| | 200 | 300 | 400 | W 2:1 |
| Start time | Not capacitive load | | | 20mS |

Remote On/Off Function

| | | | | |
|-----|----------------------|--|--|-----|
| CTL | CNT Pin connect -Vin | | | OFF |
| | CNT Pin left open | | | ON |

Output Feature

| | | | |
|-------------------------------|---|--|-------------|
| | Test condition | | |
| Voltage accuracy | $I_o=0.1...1.0 \times I_{onom}, V_i=V_{rated}$ | | $\pm 1.0\%$ |
| Line regulation | $V_{imin} \leq V_i \leq V_{imax}$ | | $\pm 0.2\%$ |
| Load regulation | $I_o=0.1...1.0 \times I_{onom}, V_{imin} \leq V_i \leq V_{imax}, V_i=V_{rated}$ | | $\pm 0.5\%$ |
| Ripple&noise | 2-MHz Broadband | | 1% |
| Over current protection | $V_{imin} \leq V_i \leq V_{imax}$ | | 120% |
| Peak Deviation | 25% Rated Load Vary | | $\pm 5.0\%$ |
| Dynamic Response Setting Time | | | 400us |
| Output Voltage Trim | $V_{imin} \leq V_i \leq V_{imax}$ | | 10% |
| Switching frequency | $V_{imin} \leq V_i \leq V_{imax}$ | | 300KHz |

General Feature

| | | | |
|---------------------------------|----------------|--|--|
| | Test condition | | |
| Efficiency | | | 85% typical |
| Board temperature | Industry level | | $-25^\circ\text{C} \sim +55^\circ\text{C}$ |
| Working environment temperature | Military level | | $-25^\circ\text{C} \sim +85^\circ\text{C}$ |
| Max Board temperature | Industry level | | $+85^\circ\text{C}$ |
| | Military level | | $+105^\circ\text{C}$ |

| | | | |
|-------------------------|---|---|-----------------------|
| Storage temperature | Industry level | | -40℃ ~ +105℃ |
| | Military level | | -50℃ ~ +105℃ |
| Relative humidity | No condensation | | 5%~90%RH |
| Temperature coefficient | | | ±0.02%/℃ |
| case material | | | aluminium baseplate |
| Isolated resistance | Input-Output | | 100M ohm |
| Vibration resistance | 10~55Hz | | 5G |
| Over current mode | Full input range | Protection type : Hiccup mode, recovers automatically | |
| Cooling | | Heatsink,nature cooling | |
| Case material | | epoxy,Aluminum base plate | |
| Isolated Voltage | Input-output 1500Vdc; input-FG 1500Vdc,Output-FG 500Vdc | | |
| MTBF | MIL-HDBK-217F2 | | 5X10 ⁶ Hrs |

Product Nomination Method

| | | | |
|---------|----------------------------------|-----|-----------------------|
| example | L D 200 - G 48 S 12 | | |
| | ① ② ③ | ④ ⑤ | ⑥ ⑦ |
| ① | Wide input voltage: 2: 1 | ④ | G:1/4 brick package |
| ② | Power adaptation mode: D (DC-DC) | ⑤ | Normal input voltage |
| ③ | Output power(W) | ⑥ | S=Single route output |
| ⑦ | output voltage | | |

Product Program

| PART # | Input voltage range | Output voltage / current | | | | | |
|--------------|---------------------|--------------------------|-------|-----|---|-----|---|
| | | VO1 | | VO2 | | VO3 | |
| | | V | A | V | A | V | A |
| LD100G-12S12 | 12V(9~18V) | 12V | 8.33A | | | | |
| LD100G-12S15 | | 15V | 6.67A | | | | |
| LD100G-12S24 | | 24V | 4.17A | | | | |
| LD100G-12S28 | | 28V | 3.57A | | | | |
| LD100G-12S48 | | 48V | 2.08A | | | | |
| LD100G-18S12 | 18V(9-36V) | 12V | 8.33A | | | | |
| LD100G-18S15 | | 15V | 6.67A | | | | |
| LD100G-18S24 | | 24V | 4.17A | | | | |

| | | | | | | | |
|---------------|----------------|-------------|-------|-------|--|--|--|
| LD100G-18S28 | | 28V | 3.57A | | | | |
| LD100G-18S48 | | 48V | 2.08A | | | | |
| LD100G-24S3V3 | 24V(18~36V) | 3.3V | 30.3A | | | | |
| LD100G-24S05 | | 5V | 20.0A | | | | |
| LD100G-24S12 | | 12V | 8.33A | | | | |
| LD100G-24S15 | | 15V | 6.67A | | | | |
| LD100G-24S24 | | 24V | 4.17A | | | | |
| LD100G-24S28 | | 28V | 3.57A | | | | |
| LD100G-24S48 | | 48V | 2.08A | | | | |
| LD100G-36S12 | | 36V(18~72V) | 12V | 8.33A | | | |
| LD100G-36S15 | 15V | | 6.67A | | | | |
| LD100G-36S24 | 24V | | 4.17A | | | | |
| LD100G-36S28 | 28V | | 3.57A | | | | |
| LD100G-36S48 | 48V | | 2.08A | | | | |
| LD100G-48S3V3 | 48V(36~72V) | 3.3V | 30.3A | | | | |
| LD100G-48S05 | | 5V | 2.00A | | | | |
| LD100G-48S12 | | 12V | 8.33A | | | | |
| LD100G-48S15 | | 15V | 6.67A | | | | |
| LD100G-48S24 | | 24V | 4.17A | | | | |
| LD100G-48S28 | | 28V | 3.57A | | | | |
| LD100G-48S48 | | 48V | 2.08A | | | | |
| LD100G-110S05 | 110V(65~150V) | 5V | 20.0A | | | | |
| LD100G-110S12 | | 12V | 8.33A | | | | |
| LD100G-110S15 | | 15V | 6.67A | | | | |
| LD100G-110S24 | | 24V | 4.17A | | | | |
| LD100G-110S28 | | 28V | 3.57A | | | | |
| LD100G-110S48 | | 48V | 2.08A | | | | |
| LD100G-300S05 | 300V(200~400V) | 5V | 20.0A | | | | |
| LD100G-300S12 | | 12V | 8.33A | | | | |
| LD100G-300S15 | | 15V | 6.67A | | | | |
| LD100G-300S24 | | 24V | 4.17A | | | | |
| LD100G-300S28 | | 28V | 3.57A | | | | |
| LD100G-300S48 | | 48V | 2.08A | | | | |

Recommended Circuit

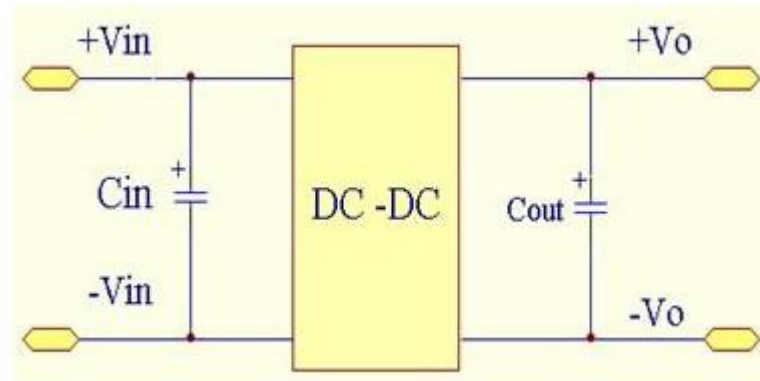

- (1) Power module with C_{in} is helpful to improve the electromagnetic compatibility, it is recommended to use $47\mu F \sim 100\mu F$ electrolytic capacitor
- (2) Power module with C_{out} is helpful to lower the output ripple
- (3) Power module output connects the digital circuit needs to add C_{out}
- (4) C_{out} is recommended to use $100\mu F/A$, the current is refers to the output current

TRIM

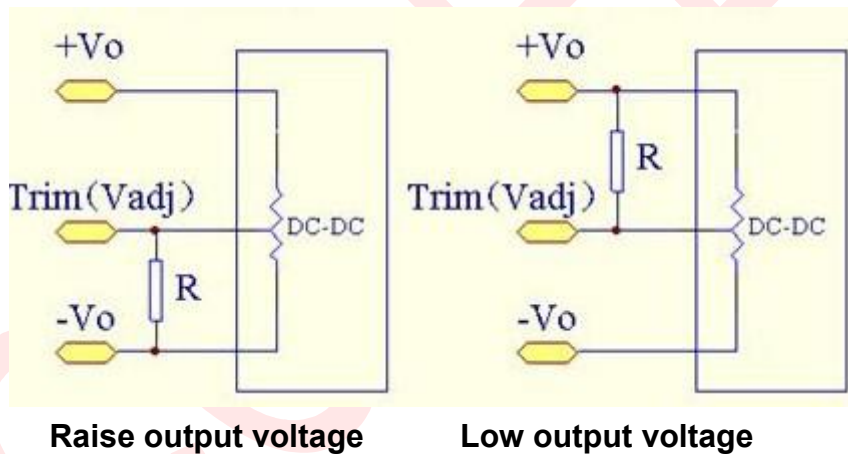

Input voltage--Efficiency

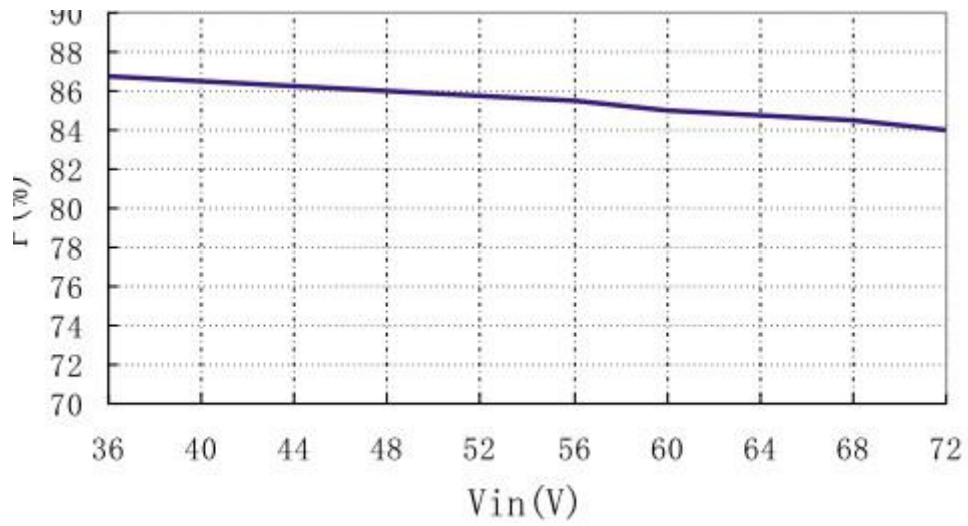

Output Load--Efficiency

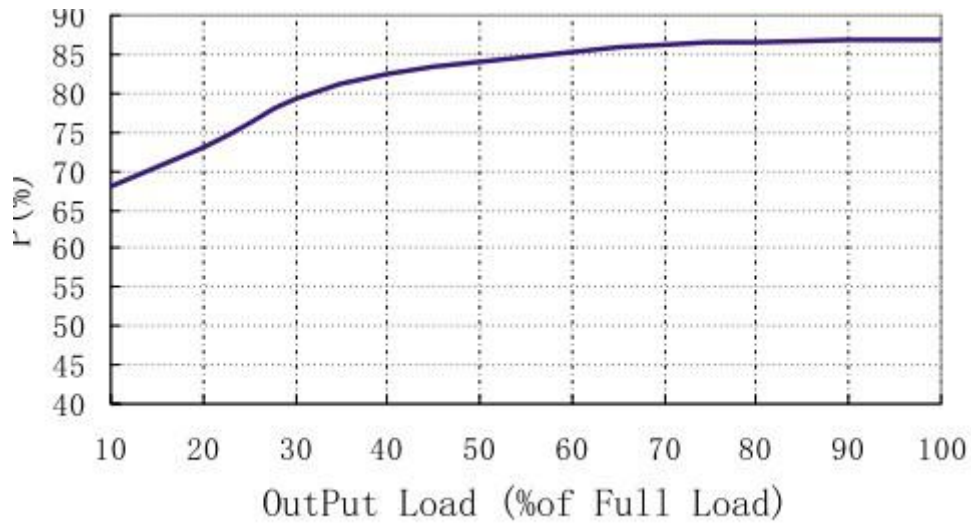

Temperature Curve

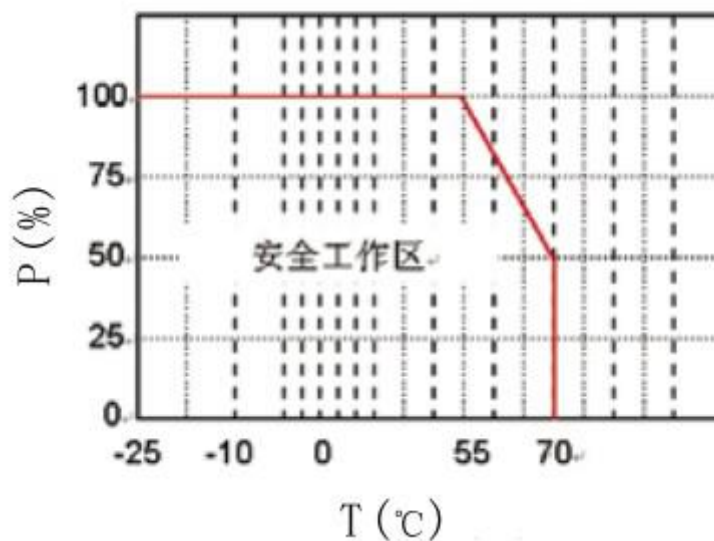

Mechanical Dimension

【外观图】

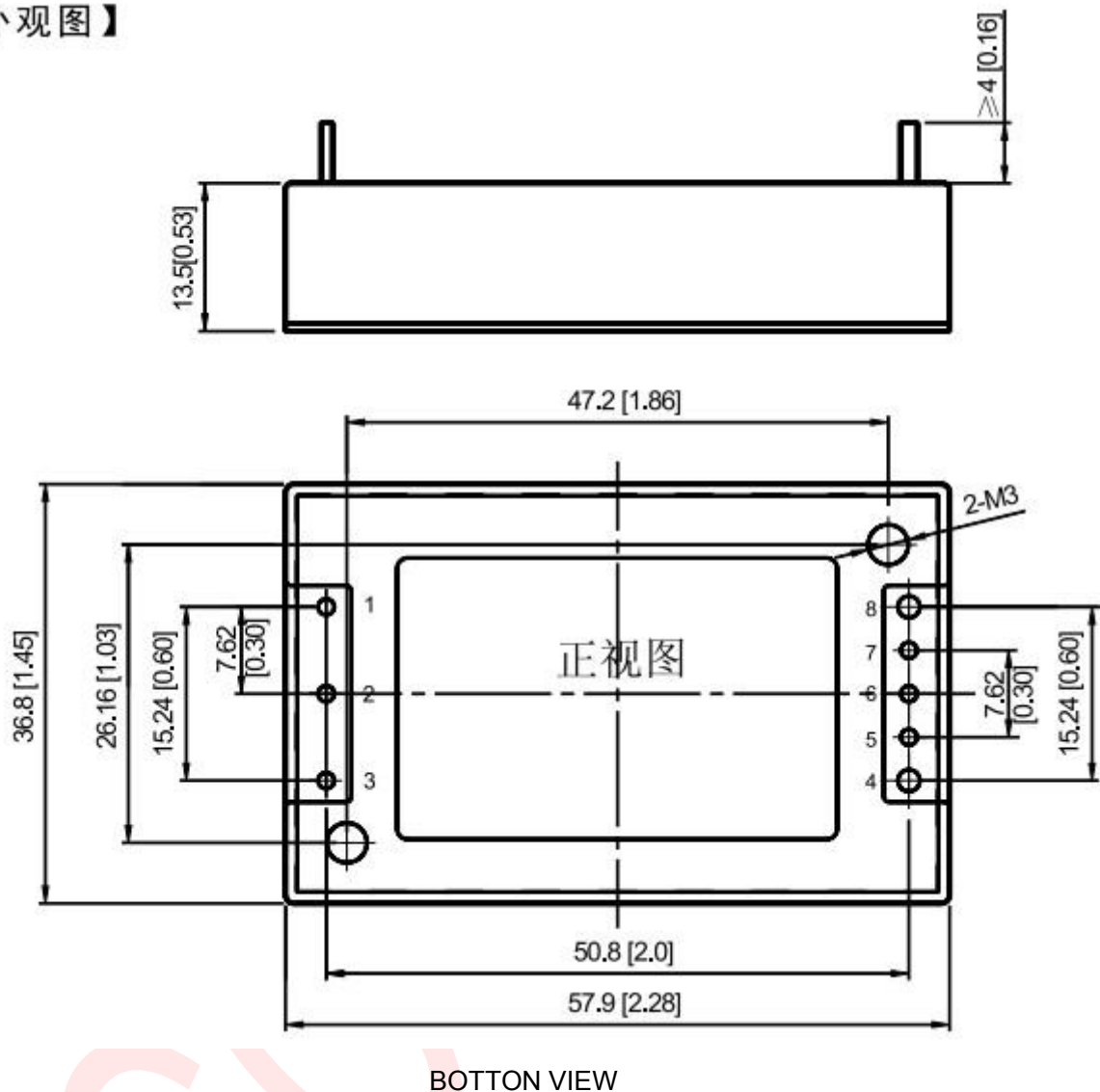

Unit:mm(inch)

Tolerance:±0.2mm(±0.008inch)

Mechanical Data

| WATT | L x W x H | Packing No. |
|------|------------------|-------------|
| 100W | 57.9*36.8*12.7mm | |

Pin Assignment

| Pin | 1 | 2 | 3 | 4 | 5 | 6 | 7 | 8 | | |
|------------|------|-----|------|-----|----|------|----|-----|--|--|
| Single O/P | -Vin | CTL | +Vin | +Vo | +S | TRIM | -S | -Vo | | |

*Note: The power modules such as the definition of the pin does not match with the hand book, please refer to the actual item.